

I | PRAXIS ORGANISATION | WO  
I | PRACTICE ORGANIZATION | WO  
I | ORGANISATION DU CABINET | WO



## variable

Instrumente sind mit einer Länge von 171 mm perfekt auf das System abgestimmt. Im größten GPM Tray können Instrumentenstege horizontal und vertikal eingelegt werden – beste Raumnutzung.

Instruments with a length of 171 mm are perfectly tailored to the system. The instrument racks can be placed horizontally and vertically in the largest GPM tray – for maximum use of space.

Affichant une longueur de 171 mm, les instruments sont parfaitement adaptés au système. Les supports d'instruments peuvent être déposés à l'horizontale et à la verticale dans la plus grande cassette GPM, ce qui permet une utilisation optimale de l'espace.

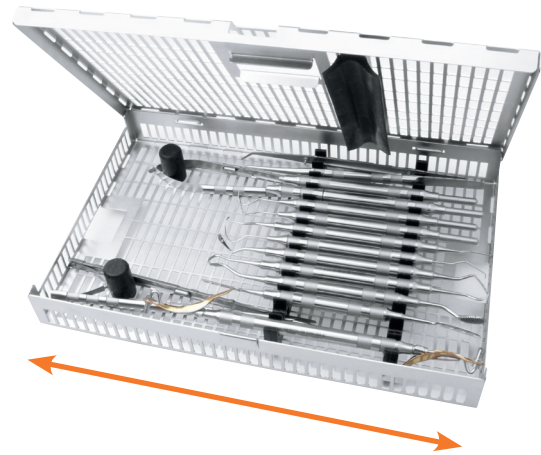
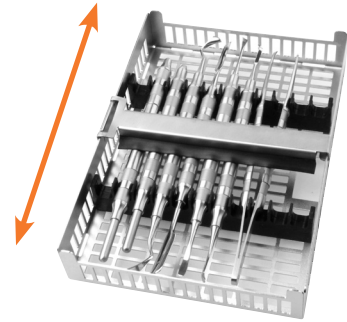

## effective cleaning

Große Perforierung gewährleistet wirkungsvolle Reinigung.  
GPM Trays werden aus rostfreiem Edelstahl hergestellt.  
Silikonleiste fixiert Instrumente optimal.

Effective cleaning is guaranteed due to the large perforations.  
GPM Trays are made of stainless steel.  
The silicone band is excellent for placing the instruments.

Grâce aux grandes perforations, ces cassettes garantissent un nettoyage optimal de vos instruments.

Les cassettes GPM sont en acier inoxydable.  
Une fixation en silicone dans le couvercle évite un déplacement des instruments.

## easy lock



Mit dem Druckverschluss *easy lock* können die Trays unkompliziert und einfach geöffnet und geschlossen werden.

The pressure-cap *easy lock* enables opening and closing very easy.

Le système de fermeture par pression *easy lock* garantit une ouverture et une fermeture confortables et faciles de la cassette.

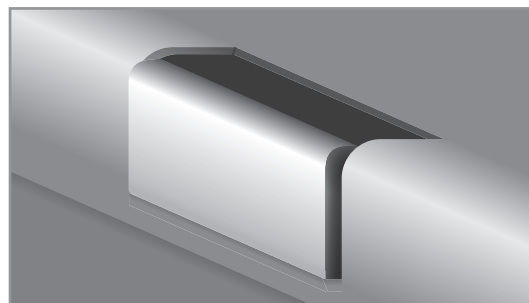

**Einfaches Öffnen:** Druckverschluss nach innen drücken und den Deckel nach oben ziehen.

**Easy opening:** Only push the button inwards and pull up the top cover.

**Ouverture simple:** Pressez le bouton à l'intérieur et soulevez le couvercle vers le haut.

**Schnelles Schließen:** Einfach den Deckel nach unten drücken.

**Quick closing:** Push down the top cover.

**Fermeture rapide:** Pressez le couvercle vers le bas facilement.

## good handling

Griff im Deckel ermöglicht einfachen und sicheren Transport

Handle in the cover facilitates safe and easy transport

Une poignée intégrée dans le couvercle de la cassette GPM permet un transport sûr et facile.

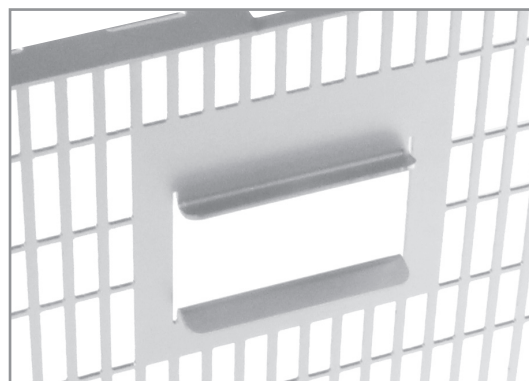

2 racks options

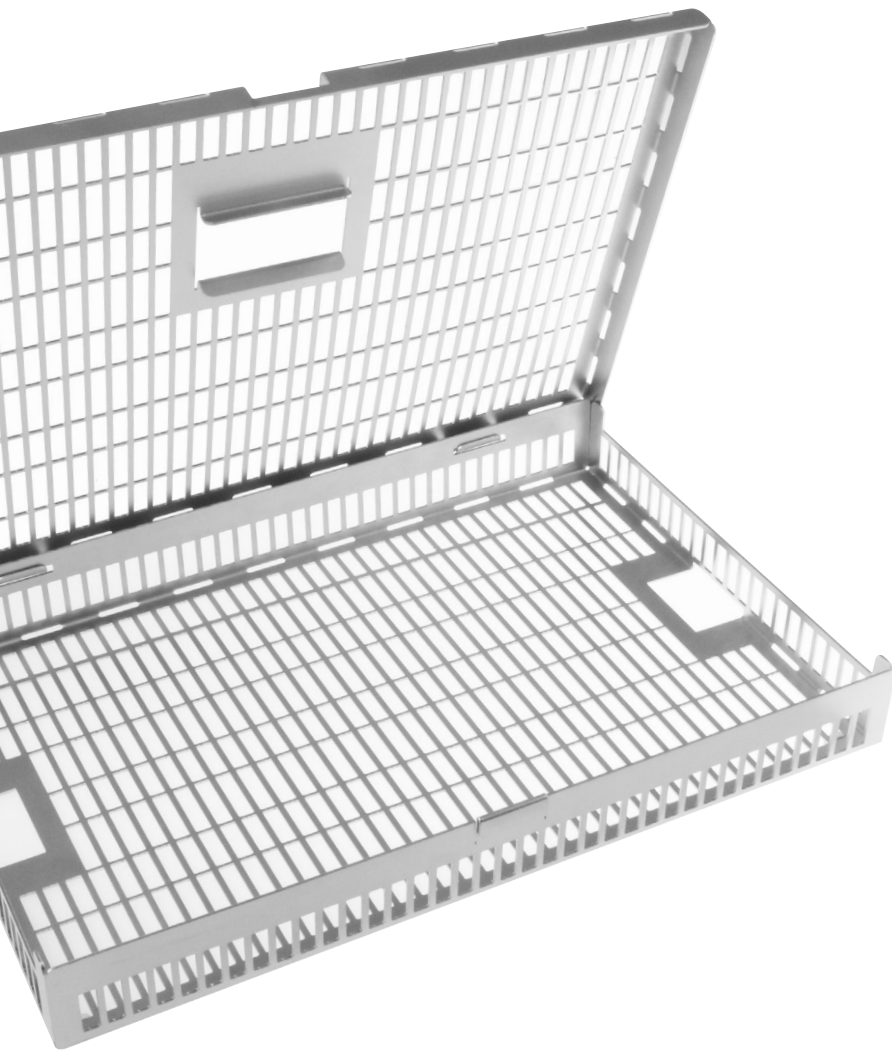

option 1

option 2

## Silikon-Stege

Silicone-Racks  
Supports en Silicone

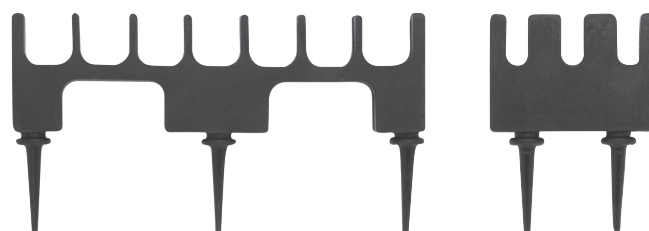

## Silikon-Formstege

Silicone Form Racks  
Supports en Silicone



## WO CLIP Trays

WO CLIP Trays

WO Cassettes de CLIP



**02-9102-05**

271,5 x 177,5 x 33,0 mm

leer  
empty  
vide



**02-9102-07**

177,5 x 127,5 x 33,0 mm

leer  
empty  
vide

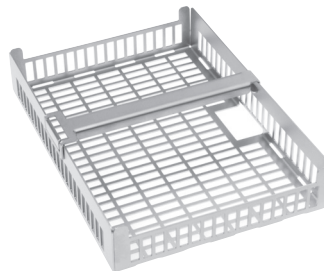

**02-9102-09**

177,5 x 84,5 x 33,0 mm

leer  
empty  
vide



## WO Wash Trays mit Deckel

WO Wash trays Stainless steel with top cover

WO Wash Cassettes en acier inoxydable avec poignée



**02-9102-00**

275 x 180 x 35 mm

leer  
empty  
vide

mit Haltegriff  
with handle  
avec poignée



**02-9102-01**

275 x 87 x 35 mm

leer  
empty  
vide

mit Haltegriff  
with handle  
avec poignée



**02-9102-02**

180,0 x 87,0 x 35,0 mm

ohne Haltegriff  
without handle  
sans poignée

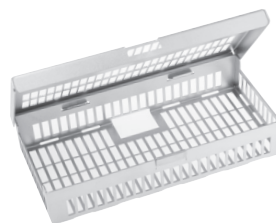

**02-9102-04**

180,0 x 130,0 x 35,0 mm

mit Haltegriff  
with handle  
avec poignée



## WO Trays mit **Silikon-Stegen**

WO Trays with **Silicone-Racks**

WO Cassettes avec Supports en **Silicone**



Diese neuen Silikonstege sind eine Alternative zu unseren bewährten Teflonstegen. Das Silikon verhindert das Herumrutschen der Instrumente im Steg sowie des Trays auf dem Tisch. Durch die Montagehilfen (Stifte) werden keine Schrauben mehr benötigt und Beschädigungen der Unterlage werden ausgeschlossen.



These new silicone bars are an alternative to our Teflon bars. The silicone prevents the instruments from sliding at the bar as well as of the tray on the table. The mounting aids (pins) eliminate the need for screws and prevent damage to the base.



Ces nouveaux supports en silicone constituent une alternative à nos supports de Teflon. Le silicone prévient tout glissement des instruments sur le support ainsi que de la cassette sur la table. Grâce aux pivots de montage, plus aucune vis n'est nécessaire et il est ainsi possible d'exclure toute détérioration de la base.

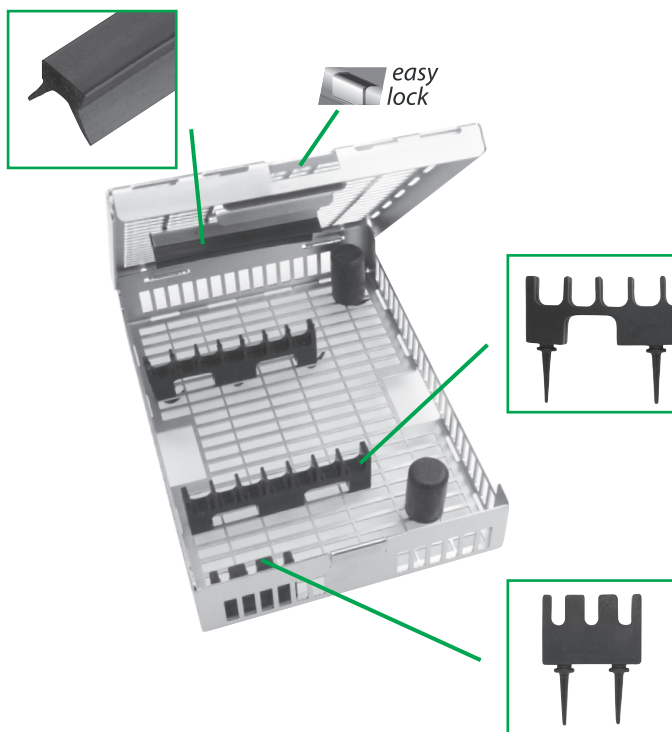

- especially suitable for superlight handles
- no screws necessary
- storage on two levels
- no slithering on the table or inside the rack
- easily and fast adaptable for user

Montagehilfen mit kreisenden Bewegungen durch das Tray-Gitter ziehen.

Use circular movements to pull assembly aids through the mesh of the tray.

Tirer les pivots de montage à travers le maillage de la cassette en effectuant des mouvements rotatifs.

Die Montagehilfen mit der Schere abschneiden.

Cut off the assembly aids using scissors.

Couper les pivots de montage à l'aide d'une paire de ciseaux.





## Silikon-Stege

Silicone-Racks  
Supports en Silicone

Artikel-Nr. Item no. Articles-Réf.	Instrumente Instruments Instruments	
<b>02-9900-04 S</b>	11	123,0 x 23,0 x 8,0 mm

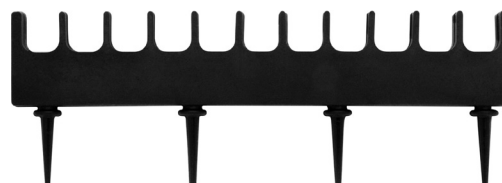

## Tray-Stege mit Brücken

Tray-Racks with bridges  
Supports en Tray avec ponts

Artikel-Nr. Item no. Articles-Réf.	Instrumente Instruments Instruments		Brücken bridges ponts
<b>02-9900-00 S</b>	14	154,7 x 23,0 x 8,0 mm	3
<b>02-9900-02 S</b>	7	79,1 x 23,0 x 8,0 mm	2



## Tray-Steg für Pinzetten

Tray-Rack for tweezers  
Support en Tray pour précelles

Artikel-Nr. Item no. Articles-Réf.	Pinzetten Tweezers Précelles	
<b>02-9900-20 S</b>	3	32,6 x 23,0 x 8,0 mm

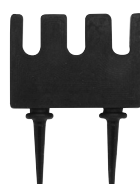

## Halterung für Ringgriffinstrumente

Holder for ring handle instruments  
Crochet pour instruments à anneaux

<b>02-9900-30 S</b>	
	28 mm
	Ø 16,5 mm



## WO Trays mit **Silikon-Stegen**

WO Trays with **Silicone Racks**

Wo Cassettes avec **Supports en Silicone**



**02-9200-80 S**

177,5 x 127,5 x 33,0 mm

für 11 Instrumente  
for 11 instruments  
pour 11 instruments



**02-9200-70 S**

177,5 x 84,5 x 33,0 mm

für 7 Instrumente  
for 7 instruments  
pour 7 instruments

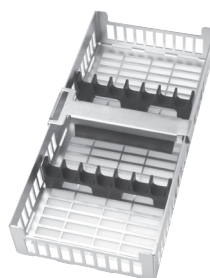

## WO Tray Bausteine

WO Tray modules

WO Éléments supplémentaires

### 02-9900-40

Fixierer	25,0 mm
Pusher	23,0 mm
Gâchette	8,0 mm



### 02-9900-50

Halterung	20,0 mm
Holder	22,0 mm
Crochet	8,0 mm



für Trennblech Art. No. 02-9900-70  
for separating plate no. 02-9900-70  
pour séparation tôle no. 02-9900-70

### 02-9900-70

Trennblech	163,0 mm
Separating plate	28,0 mm
Séparation tôle	



**02-9900-80** 155 mm

**02-9900-81** 250 mm

**02-9900-82** 68 mm

**02-9900-83** 115 mm

Silikonleiste für Traydeckel  
Silicone band for tray cover  
Joint en silicone pour couvercle



**02-9900-90** 155 mm

**02-9900-92** 68 mm

**02-9900-93** 115 mm

Metallführung für Silikonleiste  
Metal guides for silicone band  
Barre métallique pour joint en silicone



## WO Trays mit Silikon-Formstegen

WO Trays with Silicone-Form Racks

WO Cassettes avec Supports en Silicone en forme

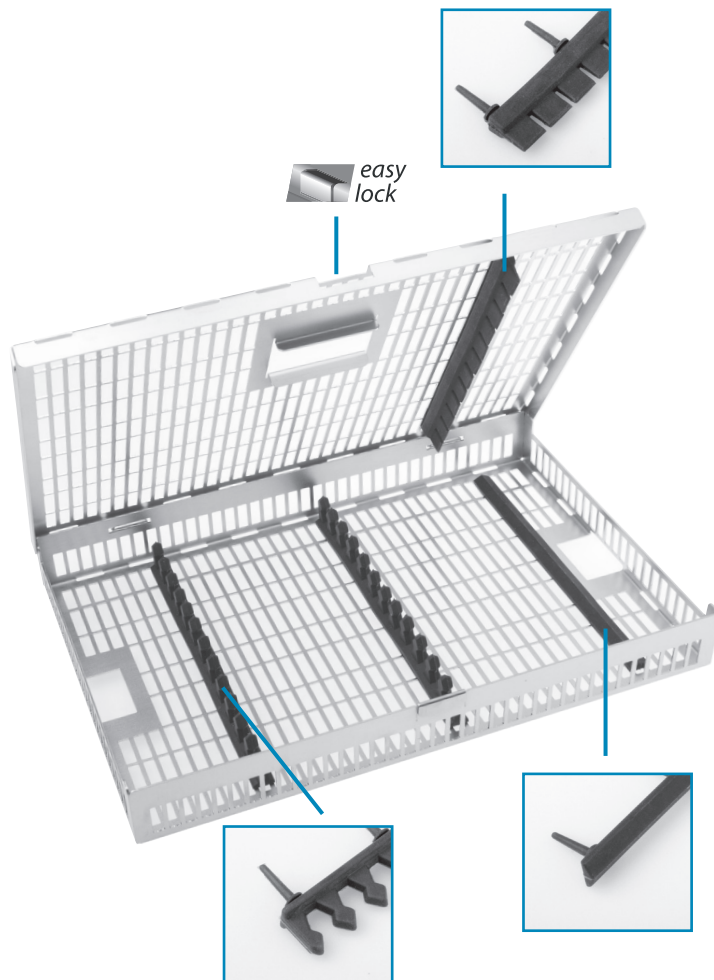

- suitable for all instruments
- no screws necessary
- no slithering on the table or inside the rack
- easily and fast adaptable for user
- individual cutting with scissors

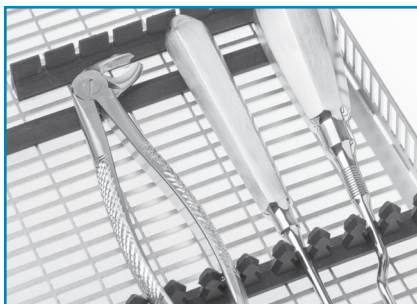

Besonders geeignet für Instrumente wie Zangen, Hebel...

Particularly suited to instruments such as forceps, levers, ...

Convient particulièrement aux instruments comme les pinces, leviers, ...



Flexibel einsetzbar durch das Nachgeben der Zapfen.

Flexible positioning due to the adaptable pegs.

Utilisation flexible grâce au relâchement des ergots.

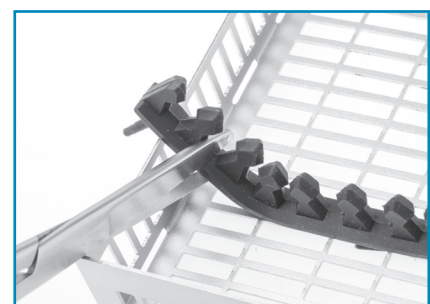

Schnelles und einfaches Anpassen der Silikonsteglänge mit der Schere.

Fast and easy adjustment of the length of the silicone racks using scissors.

Ajustement rapide et simple de la longueur des supports en silicone à l'aide d'une paire de ciseaux.

## Silikon-Formstege

Silicon-Form Racks

Supports en Silicone en forme

### 02-9901-10

# 12

16,0 mm

17,0 mm

10,0 mm

geformt  
shaped  
profilé



### 02-9901-50

Niederhalter

16,0 mm

downholder

17,0 mm

Dispositif de retenue

7,0 mm

hoch  
tall  
haut

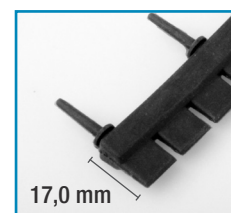

### 02-9901-20

Universal

16,0 mm

17,0 mm

5,0 mm

flach  
plane  
plate

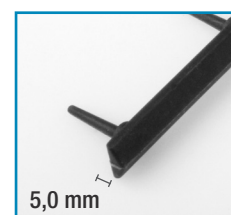

Montagehilfen mit kreisenden Bewegungen durch das Tray-Gitter ziehen.

Use circular movements to pull assembly aids through the mesh of the tray.

Tirer les pivots de montage à travers le mailage de la cassette en effectuant des mouvements rotatifs.

Die Montagehilfen mit der Schere abschneiden.

Cut off the assembly aids using scissors.

Couper les pivots de montage à l'aide d'une paire de ciseaux.

## GPM Aluminium Container

GPM Aluminium container

GPM Containers en aluminium



### GPM Container:

- passend für alle nach Norm gefertigten Autoklaven
- kompatibel zu den GPM Wash Trays
- aus Aluminium hergestellt
- Deckeldichtung aus Silikon gewährleistet einen absolut sicheren Verschluss des Containers
- Verschlussystem ermöglicht ein hygienisch einwandfreies Öffnen und Schliessen des Containers
- stapelbar
- 6 Monate Lagerzeit nach DIN 58953
- mit gelochtem Boden und Deckel
- nur für Dampfsterilisation im Gravitations- und fraktionierten Vakuumverfahren
- sicherer Transport des Sterilguts
- Sicherheitssiegel schützen gegen unbeabsichtigtes Öffnen des Containers
- lange Lebensdauer
- Kosten für Einweg-Sterilverpackungen entfallen
- keine Umweltbelastungen durch Einweg-Sterilverpackungen

Die Dimensionen unserer GPM Container und GPM Trays wurden vollständig aufeinander abgestimmt.

Unten finden Sie eine Übersicht, wie Sie unsere GPM Trays in unsere Standard GPM Container einsetzen können.

Container-Ansicht von oben:

Container view from above:

Container-vue de haut:



### GPM Container:

- suitable for all standard manufactured autoclaves
- compatible with the GPM Wash Trays
- manufactured from aluminium
- the silicone cover seal guarantees that the container will be securely locked
- the locking system ensures hygienically perfect opening and closing of the container
- stackable
- 6 months storage time, in accordance to DIN 58953
- with perforated base and top cover
- only suitable for steam sterilization by the gravitational or fractional vacuum method
- safe transportation of sterile materials
- safety seals prevent accidental opening of the container
- long service life
- no additional costs for disposable aseptic packaging
- no negative environmental impact through the use of disposable aseptic packaging

The dimensions of our GPM containers and GPM Trays are completely coordinated.

Below you can find an overview of how our GPM-trays can be used with our standard GPM containers.



### GPM Container:

- adaptables à tous les autoclaves de norme
- compatibles avec les GPM cassettes
- fabriqués en aluminium
- des joints en silicone dans le couvercle garantissent une fermeture sécurisée du container
- nouveau système de fermeture qui permet une ouverture et fermeture hygiénique du container
- se laissent superposer
- stockage pendant 6 mois selon DIN 58953
- avec couvercle et fond perforé
- uniquement pour stérilisation à la vapeur procédé avec vide fractionné ou gravitation
- un transport sûr des instruments stérilisés
- des plombs de sécurité protègent contre une ouverture involontaire du container
- vu la durée de vie des containers, ils sont économiques
- aucun coût pour des emballages stériles jetables
- plus écologique que les emballages jetables

Les dimensions de nos GPM containers et de nos GPM cassettes permettent une compatibilité parfaite.

Vous trouvez ci-dessous un aperçu comment placer nos GPM cassettes dans nos GPM containers standard.

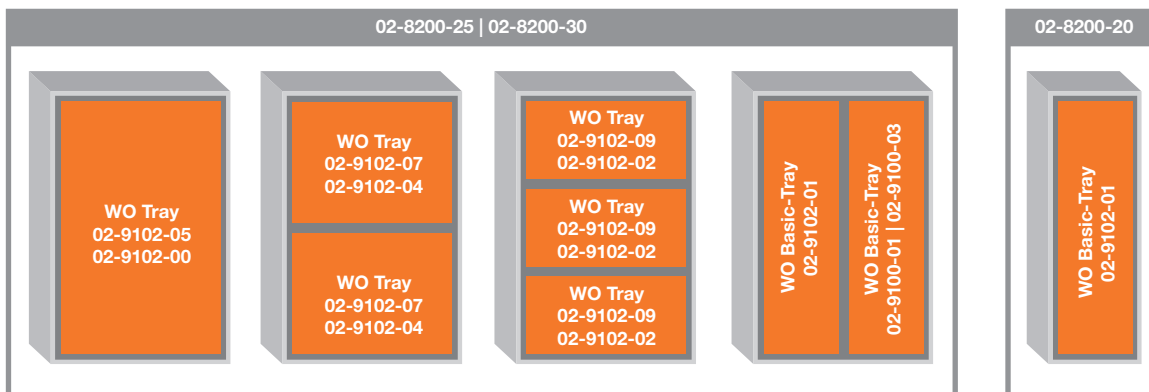

## GPM Aluminium Container

GPM Aluminium container  
GPM Containers en aluminium

### 02-8200-20

ca. 310 x 190 x 65 mm

Deckel und Boden perforiert  
Perforated cover and base  
Couvercle et fond perforé



### 02-8200-25

ca. 310 x 190 x 100 mm

Deckel und Boden perforiert  
Perforated cover and base  
Couvercle et fond perforé

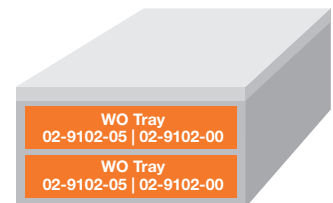

### 02-8200-30

ca. 310 x 190 x 130 mm

Deckel und Boden perforiert  
Perforated cover and base  
Couvercle et fond perforé

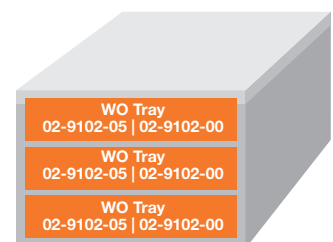

Das Design der Container kann künftig leicht abweichen.  
The design of the containers may vary slightly.  
Le design du conteneur peut légèrement différer.



## GPM Papierfilter

GPM Paper filter

GPM Filtre en papier

### 02-8200-90

100 Stück	145 mm
100 pieces	215 mm
100 pièces	

für Dental Container Art. Nr. 02-8200-20, -25, -30  
for Dental Container Art. No. 02-8200-20, -25, -30  
pour Dental Container Art. No. 02-8200-20, -25, -30



## GPM Dauerfilter (für 1200 Sterilisationszyklen)

GPM Permanent filter (for 1200 sterilization cycles)

GPM Filtre permanent (pour 1200 cycles de stérilisation)

### 02-8200-91

	145 mm
	215 mm

für Dental Container Art. Nr. 02-8200-20, -25, -30  
for Dental Container Art. No. 02-8200-20, -25, -30  
pour Dental Container Art. No. 02-8200-20, -25, -30



## GPM Aluminium Container | Zubehör

GPM Aluminium container | Accessories

GPM Containers en aluminium | Accessoires

### 02-8300-11

Sicherheitssiegel, Kunststoff  
Safety seal, plastic  
Plomb de sécurité en plastique

100 Stück  
100 pieces  
100 pièces



**02-8300-15** 600 x 400 mm

**02-8300-16** 650 x 650 mm

**02-8300-17** 850 x 850 mm

Einschlagtuch  
Surgery drape  
Champ opératoire



<b>02-8300-31</b>	gelb
<b>02-8300-32</b>	rot
<b>02-8300-33</b>	blau
<b>02-8300-34</b>	grün
<b>02-8300-35</b>	schwarz

Kennzeichnungsschild, neutral  
Identification label without inscription  
Plaque d'identification sans inscription

<b>02-8300-21</b>	gelb
<b>02-8300-22</b>	rot
<b>02-8300-23</b>	blau
<b>02-8300-24</b>	grün
<b>02-8300-25</b>	schwarz

Kennzeichnungsschild, beschriftet  
Identification label with inscription  
Plaque d'identification avec inscription



Beschriftung nach Absprache  
Labeling by agreement  
Marquage en accord



## GPM Aluminium Container | Zubehör

GPM Aluminium container | Accessories

GPM Containers en aluminium | Accessoires

### 02-8300-10

Indikatorschild

Label with indicator

Indicateur

100 Stück

100 pieces

100 pièces



### 02-8300-40

Sortiermagazin

Sorter

Magasin

für Kennzeichnungsschilder

for identification labels

pour plaques d'identification



### 02-9360-25

Nierenschale

250 mm

Kidney bowl

140 mm

Bassins réniformes

40 mm



### 02-9390-17

Runde Schale

Ø 175 mm

Solution bowl

70 mm

Cuvette ronde

1 Liter



## Glasplatten zum Anmischen

Glass plates for mixing

Plaques de verre

### 02-9990-01

95 mm

70 mm

4 mm



### Maniküre Etuis

Manicure cases

Etuis de manicure



Made in Germany



02-1159



02-1159-1

